



# EFL1002

## 10.0 T Li-ion Counterbalance Forklift Truck

- IC forklift design with li-Ion technology
- Li-Ion battery for opportunity charging & flexibility
- Multi chargers fulfilling different needs
- Market-proven components providing high durability

**LI-ION**  
TECHNOLOGY

**EP EQUIPMENT CO.,LTD**  
[www.ep-equipment.com](http://www.ep-equipment.com)



## FEATURE

### Li-ion technology

The EFL1002 adapts LFP Li-ion battery and there is no maintenance fee with no air filter, oil filter, engine oil or starter battery installed on the truck. Thanks to opportunity charging, this forklift can be charged at preferable time during the day without disrupting working schedules.

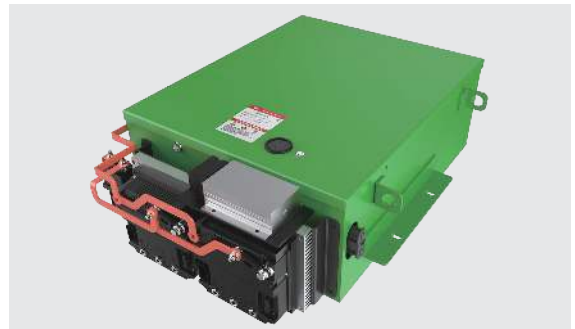

### Thoughtful control strategy for operation safety

The EFL1002 comes with a BMS which consists of a master controller and two slave controllers, to lower the risks of truck suspension due to battery failure. When one slave controller is down, operators are able to drive the truck back to the shop for inspection and repair without calling for roadside assistance.

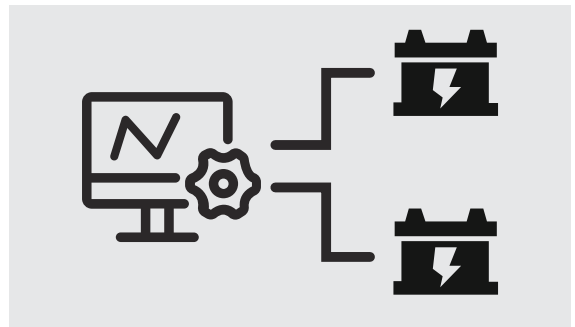

### Multi chargers fulfilling different needs

The EFL1002 is equipped with an external three-phase charger as standard. To meet users' working shifts and conditions, dual chargers are available, which provides more flexibility and convenience.



### Telematics

EFL1002 offers EP's latest Telematics. It provides the following features to facilitate your fleet management:

- Truck location in real-time
- Reports of truck usages and diagnosis
- Li-ion battery condition analytics



### Market-proven components providing high durability

The EFL1002 features a strong chassis, which ensure a naturally long lifespan and durability.



# 10.0 T Li-ion Counterbalance Forklift Truck

## EFL1002

Distinguishing mark	1.1	Manufacturer			EP	
	1.2	Model designation			EFL1002	
	1.3	Drive			Electric	
	1.4	Operator type			Seated	
	1.5	Load capacity	Q	kg	10000	
	1.6	Load center distance	c	mm	600	
	1.8	Load distance, centre of drive axle to fork	x	mm	728	
	1.9	Wheelbase	y	mm	2800	
	Service weight	2.1	Service weight		kg	14420
2.2		Axle loading, laden front/rear		kg	21610/2810	
2.3		Axle loading, unladen front/rear		kg	6670/7750	
Tyres/chassis	3.1	Tyre type			Pneumatic	
	3.2	Tyre size, front			9.00-20-14PR	
	3.3	Tyre size, rear			9.00-20-14PR	
	3.5	Wheels, number front/rear (x=drive wheels)		mm	4/2	
	3.6	Tread width, front	b10	mm	1600	
	3.7	Tread width, rear	b11	mm	1700	
Dimensions	4.1	Tilt of mast/fork carriage forward/backward	$\alpha/\beta$	°	6/12	
	4.2	Retracted mast height	h1	mm	2850	
	4.3	Free lift	h2	mm	200	
	4.4	Lift height	h3	mm	3000	
	4.5	Height, mast extended	h4	mm	4420	
	4.7	Height of overhead guard (cabin)	h6	mm	2560	
	4.8	Seat height/standing height	h7	mm	1450	
	4.12	Tow coupling height	h10	mm	524	
	4.19	Overall length	l1	mm	5730	
	4.20	Length to face of forks	l2	mm	4210	
	4.21	Overall width	b1/b2	mm	2242	
	4.22	Fork dimensions	s/e/l	mm	80X160X1520	
	4.23	A,B Fork carriage class/type A, B			5A	
	4.24	Fork carriage width	b3	mm	2210	
	4.31	Ground clearance, laden, below mast	m1	mm	190	
	4.32	Ground clearance, center of wheelbase	m2	mm	340	
	4.34.1	Aisle width for pallets 1000×1200 crossways	Ast	mm	5838	
	4.34.2	Aisle width for pallets 800×1200 lengthways	Ast	mm	6038	
	4.35	Turning radius	Wa	mm	3910	
	Performance data	5.1	Travel speed, laden/unladen		km/h	13/15
5.2		Lifting speed, laden/unladen		m/s	0.27/0.32	
5.3		Lowering speed, laden/unladen		m/s	0.45/0.4	
5.5		Drawbar pull, laden/unladen		N	—	
5.6		Max. drawbar pull, laden/unladen		N	—	
5.8		Max. gradeability, laden/unladen		%	15/15	
5.10		Service brake			Hydraulic	
5.11		Parking brake			Mechanical	
Electric-engine		6.1	Drive motor rating S2 60 min		kW	30
		6.2	Lift motor rating at S3 15%		kW	24X2
	6.4	Battery voltage/nominal capacity		V/Ah	80/820	
	6.5	Battery weight		kg	—	
	Addition data	8.1	Type of drive control			AC
10.5		Steering design			Hydraulic	
10.7		Sound pressure level at the driver's ear		dB(A)	—	

If there are improvements of technical parameters or configurations, no further notice will be given.  
The diagram shown may contain non-standard configurations.

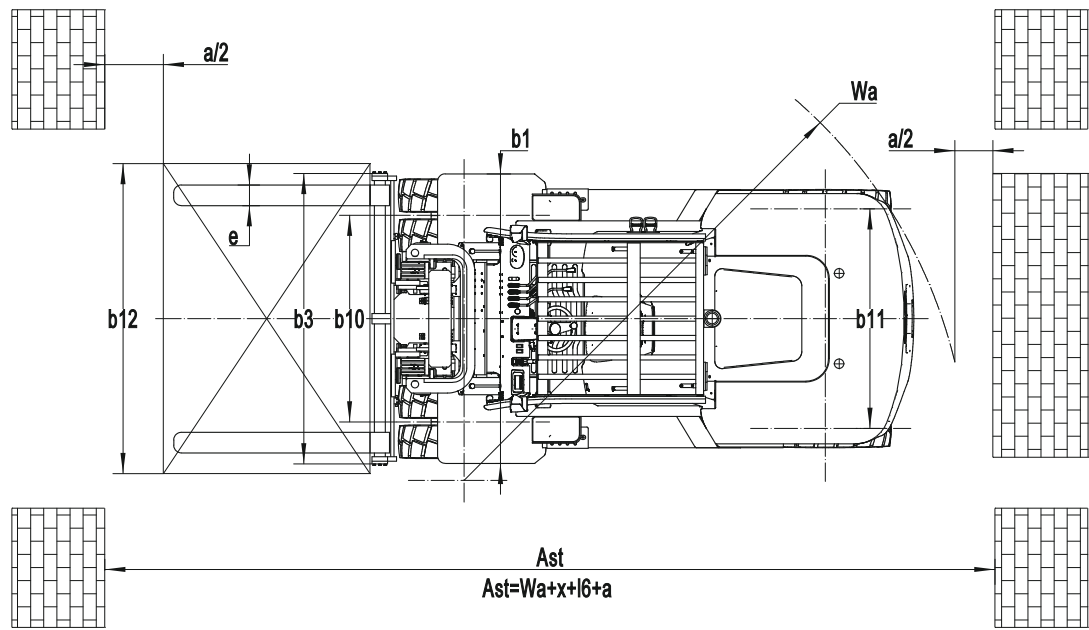
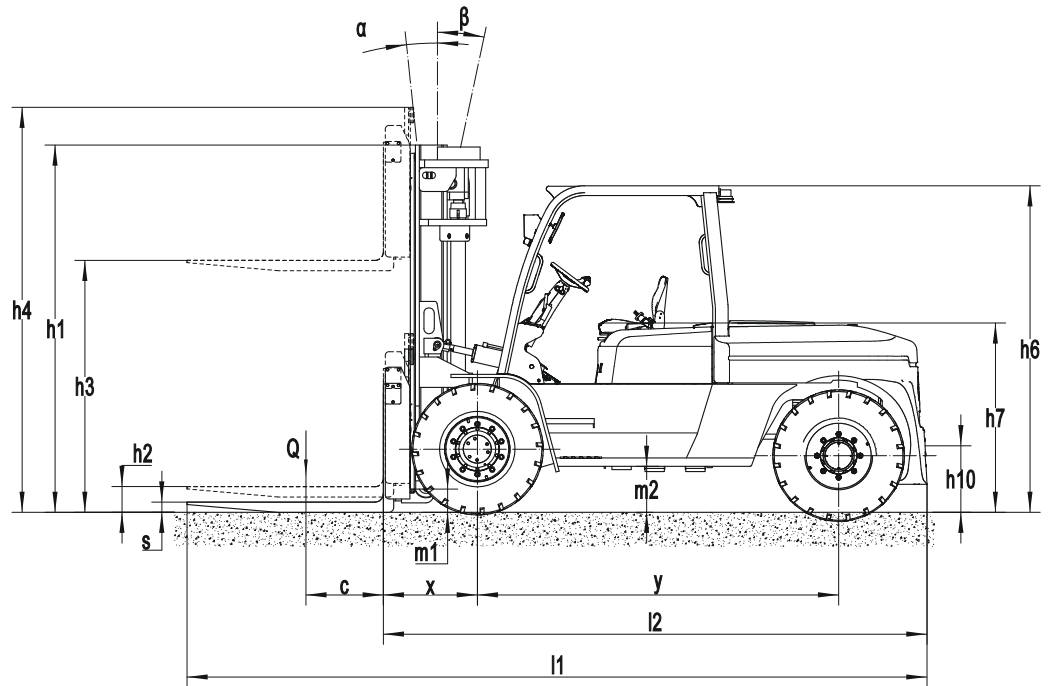

**RATED CAPACITIES AND LOAD CENTERS GRAPH**

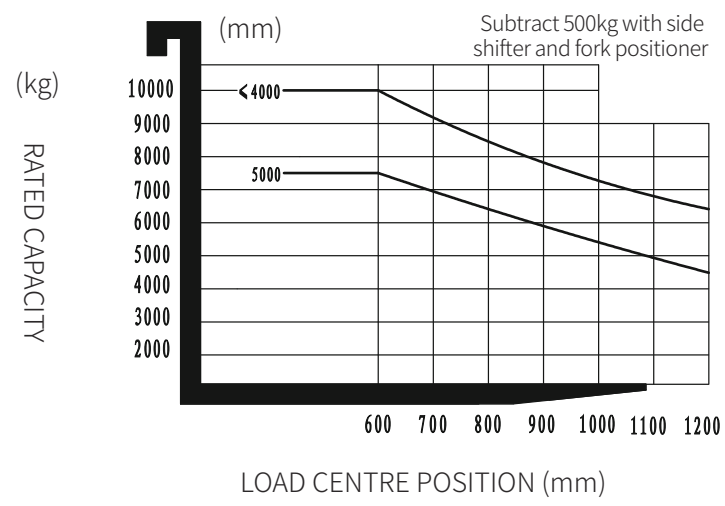

## Mast option:

Mast types	Lift height (h3)	Height, Mast			Height, Free lift(h2)	
		Height, mast lowered(h1)	Height, mast extended(h4)		No backrest	With backrest
	No backrest		With backrest	mm		
2-Standard Mast	3000	2920	4310	—	210	210
	3300	3070	4610	—	210	210
	3500	3170	4810	—	210	210
	4000	3470	5360	—	210	210
	4500	3720	5860	—	210	210
	5000	3970	6360	—	210	210
	5500	4270	6910	—	210	210
3-Free Mast	4500	2900	5875	—	1580	1580
	4800	3000	6175	—	1680	1680
	5000	3065	6375	—	1745	1745
	6000	3455	7375	—	2135	2135

## Option:

No.	Optional items	EFL1002
1.1	Fork dimension	○150*75*1520○150*75*2000●160*80*1520○160*80*1820○160*85*2000○160*85*2440
1.4	Fork carriage width	●2138mm○Yes and can be customized
1.5	Fork carriage height	●1045mm○Yes and can be customized
2.5	Front wheel material	●Pneumatic○solid○No-marking solid
2.6	Rear wheel material	●Pneumatic○solid○No-marking solid
2.7	Battery capacity	●80V820AH○80V1230AH
2.8	Charger	●80V200A○80V130A+80V130A○80V200A+80V200A
2.9	Battery indicator	●With time
2.10	Seat type	●Suspension
2.11	Attachments	●Fork positioner ○Side shift+fork positioner
2.13	Traction pin	●Yes
2.14	Electrostatic chain	●Yes
3.5	Front lamp	●LED
3.6	Rear lamp	●No○LED
3.7	Warning lamp	●Yes
3.8	Steering lamp	●Yes
3.9	Blue lamp	●No○2 front○1 rear○2 front+1 rear
3.10	Area warning lamp	●No○1 left, 1 right (Red)
3.11	Rearview mirror	● 2 rearview mirror
3.12	Hummer	●Yes
3.17	OPS system	●Yes
3.23	Telematics	●Yes
4.3	Cabin	●No○Basic half cabin○upgraded half cabin○Full cabin
4.9	Heater	●No○Yes and not customized

Note: ● standard ○ option — NA