



# EFL181

## 1800kg 4-Wheel Li-ion Counterbalance Forklift



- Compact 4 wheels 48V Li-Ion battery truck designed around I/C implemented chassis
- Indoor and outdoor use thanks to the rainproof components and the high ground clearance
- Big diameter wheels to work in every environment
- Great ergonomic design with adjustable steering wheel and comfortable bucket seat
- Powerful AC traction motor
- 48V Li-Ion battery grant efficiency, good autonomy and occasional charge
- Single phase integrated charger with 16A plug



Manufacturer			EP
Model designation			EFL181
Drive			Electric
Load capacity	Q	kg	1800
Load center distance	c	mm	500
Service weight		kg	3030
Retracted mast height	h1	mm	1995
Lift height	h3	mm	3000
Height, mast extended	h4	mm	4028
Length to face of forks	l2	mm	2015
Overall width	b1/b2	mm	1080
Fork dimensions	s/e/l	mm	40x100x920
Turning radius	Wa	mm	1920
Travel speed, laden/unladen		km/h	8.5/9
Lifting speed, laden/unladen		m/s	0.25/0.3
Lowering speed, laden/unladen		m/s	0.43/0.45
Max. gradeability, laden/unladen		%	10.5/15
Drive motor rating S2 60 min		kW	6
Battery voltage/nominal capacity		V/Ah	48/150

## FEATURE

### ■ On-board charger provides opportunity charging

Due to the usage of Li-Ion technology in combination with an onboard charger, the EFL181 is the most versatile truck you can find on the market. Plug it into any standard power outlet and the battery will be opportunity charged. No need for any external charging device. Just Plug&Play.



### ■ Compact size

The EFL181 is a very compact truck, while the legroom has been increased for better ergonomics.



### ■ Entry-level forklift

The EFL181 was designed as a universal forklift for the daily operation at few hours per day. The focus lies on the flexible operation, opportunity charging and worry-free technology of the truck at a great price point.



### ■ Trustworthy and mature components

EFL181 uses 10-year market tested components, which offers safety and reliability.



# Electric Forklift 1.8T

## EFL181

Distinguishing mark	1.1	Manufacturer			EP	
	1.2	Model designation			EFL181	
	1.3	Drive			Electric	
	1.4	Operator type			Seated	
	1.5	Load capacity	Q	kg	1800	
	1.6	Load center distance	c	mm	500	
	1.8	Load distance, centre of drive axle to fork	x	mm	405	
	1.9	Wheelbase	y	mm	1260	
	Service weight	2.1	Service weight		kg	3030
2.2		Axle loading, laden front/rear		kg	4395/435	
2.3		Axle loading, unladen front/rear		kg	1300/1730	
Tyres/chassis	3.1	Tyre type			Solid rubber	
	3.2	Tyre size, front			6.5-10	
	3.3	Tyre size, rear			5.00-8	
	3.5	Wheels, number front/rear (x=drive wheels)		mm	2x/ 2	
	3.6	Tread width, front	b10	mm	905	
	3.7	Tread width, rear	b11	mm	920	
	4.1	Tilt of mast/fork carriage forward/backward	$\alpha/\beta$	°	6/ 10	
Dimensions	4.2	Retracted mast height	h1	mm	1995	
	4.3	Free lift	h2	mm	130	
	4.4	Lift height	h3	mm	3000	
	4.5	Height, mast extended	h4	mm	4028	
	4.7	Height of overhead guard (cabin)	h6	mm	2080	
	4.8	Seat height/standing height	h7	mm	1060	
	4.12	Tow coupling height	h10	mm	370	
	4.19	Overall length	l1	mm	2935	
	4.20	Length to face of forks	l2	mm	2015	
	4.21	Overall width	b1/b2	mm	1080	
	4.22	Fork dimensions	s/e/l	mm	40×100×920	
	4.23	A,B Fork carriage class/type A, B			2A	
	4.24	Fork carriage width	b3	mm	1040	
	4.31	Ground clearance, laden, below mast	m1	mm	115	
	4.32	Ground clearance, center of wheelbase	m2	mm	120	
	Performance data	4.34.1	Aisle width for pallets 1000×1200 crossways	Ast	mm	3525
		4.34.2	Aisle width for pallets 800×1200 crossways	Ast	mm	3725
4.35		Turning radius	Wa	mm	1920	
Performance data	5.1	Travel speed, laden/unladen		km/h	8.5/9	
	5.2	Lifting speed, laden/unladen		m/s	0.25/ 0.3	
	5.3	Lowering speed, laden/unladen		m/s	0.43/ 0.45	
	5.5	Drawbar pull, laden/unladen		N	—	
	5.6	Max. drawbar pull, laden/unladen		N	10000	
	5.8	Max. gradeability, laden/unladen		%	10.5/15	
Electric-engine	5.10	Service brake			Hydraulic	
	5.11	Parking brake			Mechanical	
	6.1	Drive motor rating S2 60 min		kW	6	
	6.2	Lift motor rating at S3 15%		kW	7.5	
	6.4	Battery voltage/nominal capacity		V/Ah	48/150	
Addition data	6.5	Battery weight		kg	115	
	8.1	Type of drive control			AC	
	10.5	Steering design			Hydraulic	
	10.7	Sound pressure level at the driver's ear		dB(A)	70	

If there are improvements of technical parameters or configurations, no further notice will be given.  
The diagram shown may contain non-standard configurations.

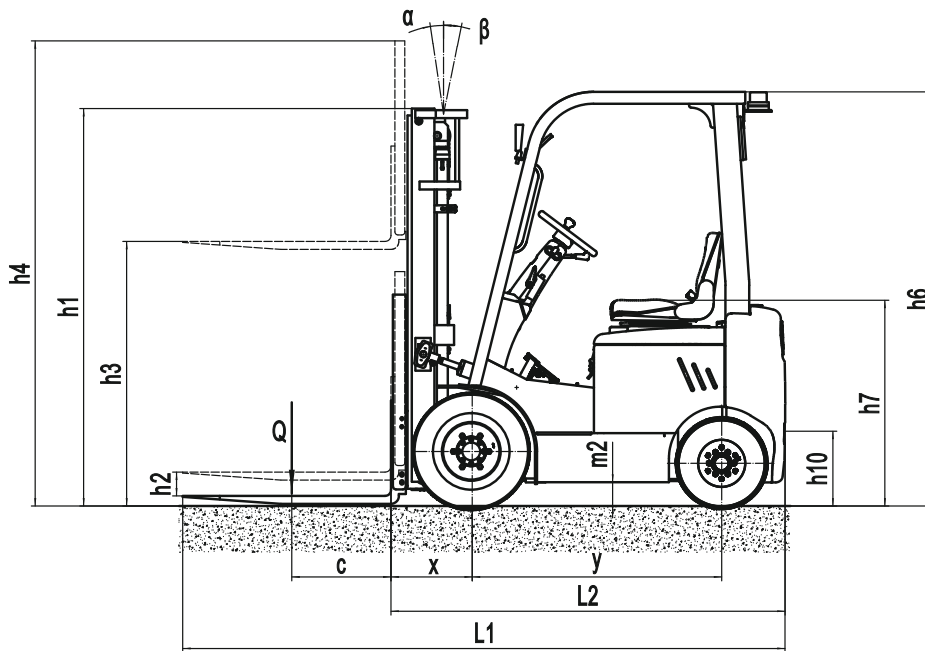
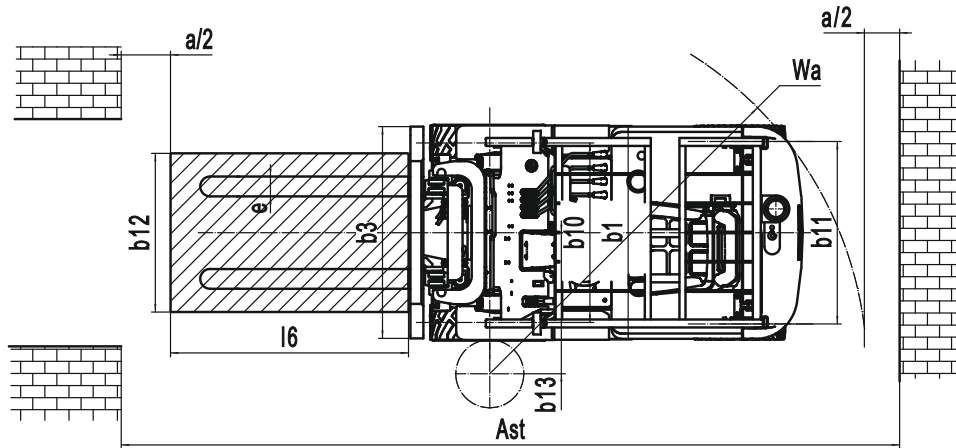

## Mast option:

Mast types	Lift height ( $h3$ )	Height, Mast			Height, Free lift( $h2$ )	
		Height, mast lowered( $h1$ )	Height, mast extended( $h4$ )		No shelving	With shelving
			No shelving	With shelving		
	mm	mm	mm	mm	mm	mm
2-Standard Mast	2500	1745	2985	3528	130	130
	2700	1845	3185	3728	130	130
	3000	1995	3485	4028	130	130
	3300	2145	3785	4328	130	130
	3600	2295	4085	4628	130	130
2-Free Mast	2500	1778	2985	3528	1293	750
	2700	1878	3185	3728	1393	850
	3000	2028	3485	4028	1543	1000
	3300	2178	3785	4328	1693	1150
3-Free Mast	4350	2000	4844	5378	1506	972
	4500	2050	4994	5528	1556	1022
	4800	2150	5294	5828	1656	1122

## RATED CAPACITIES AND LOAD CENTERS GRAPH

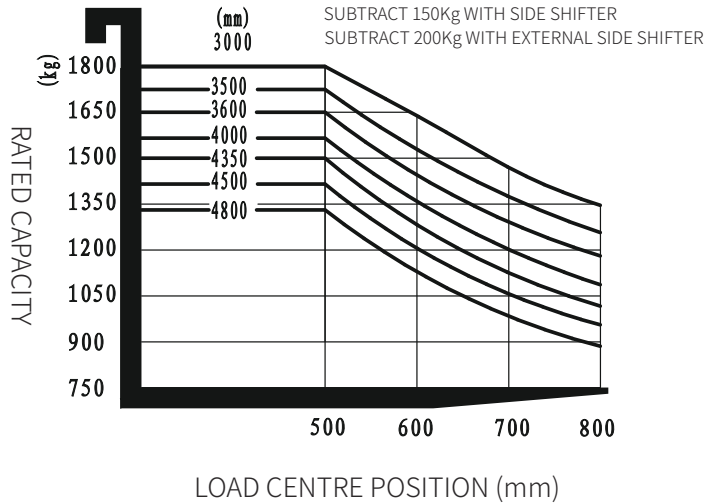

## Option:

No.	Optional items	EFL181
1.1	Fork dimension	●100*40*920○100*40*1070○100*40*1100○100*40*1150 ○100*40*1220○100*40*1370○100*40*1520○100*40*1800
1.4	Fork carriage width	●1068mm○Yes and can be customized
1.5	Fork carriage height	●1028mm○Yes and can be customized
2.5	Front wheel material	●solid○Pneumatic○Non-marking tires
2.6	Rear wheel material	●solid○Pneumatic○Non-marking tires
2.7	Battery capacity	●48V150AH○48V205AH
2.8	Charger	●48V50A○48V30A
2.10	Seat type	●TOYOTA○Suspension
2.11	Attachments	●No○Built-in sidershifter○External shifter○Adjustable fork
2.13	Traction pin	●Yes
3.5	Front lamp	●LED
3.6	Rear lamp	●NO○LED
3.7	Warning lamp	●Yes
3.8	Steering lamp	●Yes
3.9	Blue lamp	●NO○Yes and not customized
3.10	Area warning lamp	●NO○Yes and not customized
3.11	Rearview mirror	●One Rearview mirror○Two Rearview mirror
3.12	Hummer	●Yes
3.15	Fire extinguisher	●NO○Yes and not customized
3.17	OPS system	●NO○Yes and not customized
3.23	Remote monitoring	●NO○Yes and not customized
4.3	Cabin	●NO○Semi-enclosed cab, front wiper, after wiper, With electric fan

Note: ●Standard ○ Optional - Inconformity