



# EFL702

## 7000kg Li-ion Counterbalance Forklift



- Heavy duty 80 V Li-Ion battery truck designed around I/C implemented chassis
- Double front superelastic tyres
- High travelling, lifting speed and maximum gradeability
- Great ergonomic design with spacious legroom, adjustable steering wheel and comfortable bucket seat
- 80V Li-Ion battery grant efficiency, long autonomy and occasional charge
- Multi battery chargers fulfilling different needs



Manufacturer			EP
Model designation			EFL702
Drive			Electric
Load capacity	Q	kg	7000
Load center distance	c	mm	600
Service weight		kg	9600
Retracted mast height	h1	mm	2500
Lift height	h3	mm	3000
Height, mast extended	h4	mm	4430
Length to face of forks	l2	mm	3525
Overall width	b1/b2	mm	1994
Fork dimensions	s/e/l	mm	65x150x1220
Turning radius	Wa	mm	3480
Travel speed, laden/unladen		km/h	14/16
Lifting speed, laden/unladen		m/s	0.35/0.4
Lowering speed, laden/unladen		m/s	0.4/0.38
Max. gradeability, laden/unladen		%	15/20
Drive motor rating S2 60 min		kW	30
Battery voltage/nominal capacity		V/Ah	80/820

## FEATURE

### Li-ion technology

The EFL702 adapts LFP Li-ion battery and there is no maintenance fee with no air filter, oil filter, engine oil or starter battery installed on the truck. Thanks to opportunity charging, this forklift can be charged at preferable time during the day without disrupting working schedules.

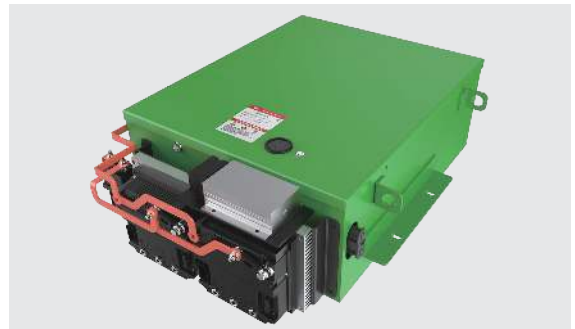

### Thoughtful control strategy for operation safety

The EFL702 comes with a BMS which consists of a master controller and two slave controllers, to lower the risks of truck suspension due to battery failure. When one slave controller is down, operators are able to drive the truck back to the shop for inspection and repair without calling for roadside assistance.

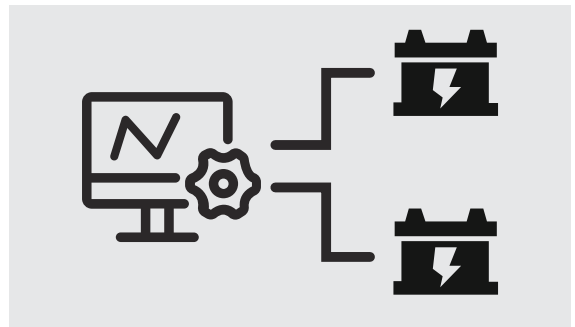

### Multi chargers fulfilling different needs

The EFL702 is equipped with an external three-phase charger as standard. To meet users' working shifts and conditions, dual chargers are available, which provides more flexibility and convenience.



### Telematics

EFL702 offers EP's latest Telematics. It provides the following features to facilitate your fleet management:

- Truck location in real-time
- Reports of truck usages and diagnosis
- Li-ion battery condition analytics



### Market-proven components providing high durability

The EFL702 features a strong chassis, which ensure a naturally long lifespan and durability.



# 7.0 T Li-ion Counterbalance Forklift Truck

## EFL702

Distinguishing mark	1.1	Manufacturer			EP
	1.2	Model designation			EFL702
	1.3	Drive			Electric
	1.4	Operator type			Seated
	1.5	Load capacity	Q	kg	7000
	1.6	Load center distance	c	mm	600
	1.8	Load distance, centre of drive axle to fork	x	mm	635
	1.9	Wheelbase	y	mm	2250
	Service weight	2.1	Service weight		kg
2.2		Axle loading, laden front/rear		kg	15020/1580
2.3		Axle loading, unladen front/rear		kg	3990/5610
Tyres/chassis	3.1	Tyre type			Pneumatic
	3.2	Tyre size, front			8.25-15-14PR
	3.3	Tyre size, rear			8.25-15-14PR
	3.5	Wheels, number front/rear (x=drive wheels)		mm	4X/2
	3.6	Tread width, front	b10	mm	1470
	3.7	Tread width, rear	b11	mm	1700
	Dimensions	4.1	Tilt of mast/fork carriage forward/backward	$\alpha/\beta$	°
4.2		Retracted mast height	h1	mm	2500
4.3		Free lift	h2	mm	170
4.4		Lift height	h3	mm	3000
4.5		Height, mast extended	h4	mm	4430
4.7		Height of overhead guard (cabin)	h6	mm	2450
4.8		Seat height/standing height	h7	mm	1390
4.12		Tow coupling height	h10	mm	310
4.19		Overall length	l1	mm	4745
4.20		Length to face of forks	l2	mm	3525
4.21		Overall width	b1/b2	mm	1994
4.22		Fork dimensions	s/e/l	mm	65X150X1220
4.23		A,B Fork carriage class/type A, B			4A
4.24		Fork carriage width	b3	mm	1995
4.31		Ground clearance, laden, below mast	m1	mm	160
4.32		Ground clearance, center of wheelbase	m2	mm	200
4.34.1		Aisle width for pallets 1000×1200 crossways	Ast	mm	5535
4.34.2		Aisle width for pallets 800×1200 crossways	Ast	mm	5535
4.35		Turning radius	Wa	mm	3480
Performance data	5.1	Travel speed, laden/unladen		km/h	14/16
	5.2	Lifting speed, laden/unladen		m/s	0.35/0.4
	5.3	Lowering speed, laden/unladen		m/s	0.4/0.38
	5.5	Drawbar pull, laden/unladen		N	—
	5.6	Max. drawbar pull, laden/unladen		N	30000
	5.8	Max. gradeability, laden/unladen		%	15/20
	5.10	Service brake			Hydraulic/ Mechanical
5.11	Parking brake			Mechanical	
Electric-engine	6.1	Drive motor rating S2 60 min		kW	30
	6.2	Lift motor rating at S3 15%		kW	24.4x2
	6.4	Battery voltage/nominal capacity		V/Ah	80V/820Ah
	6.5	Battery weight		kg	610
Addition data	8.1	Type of drive control			AC
	10.5	Steering design			Hydraulic
	10.7	Sound pressure level at the driver's ear		dB(A)	< 75

If there are improvements of technical parameters or configurations, no further notice will be given.  
The diagram shown may contain non-standard configurations.

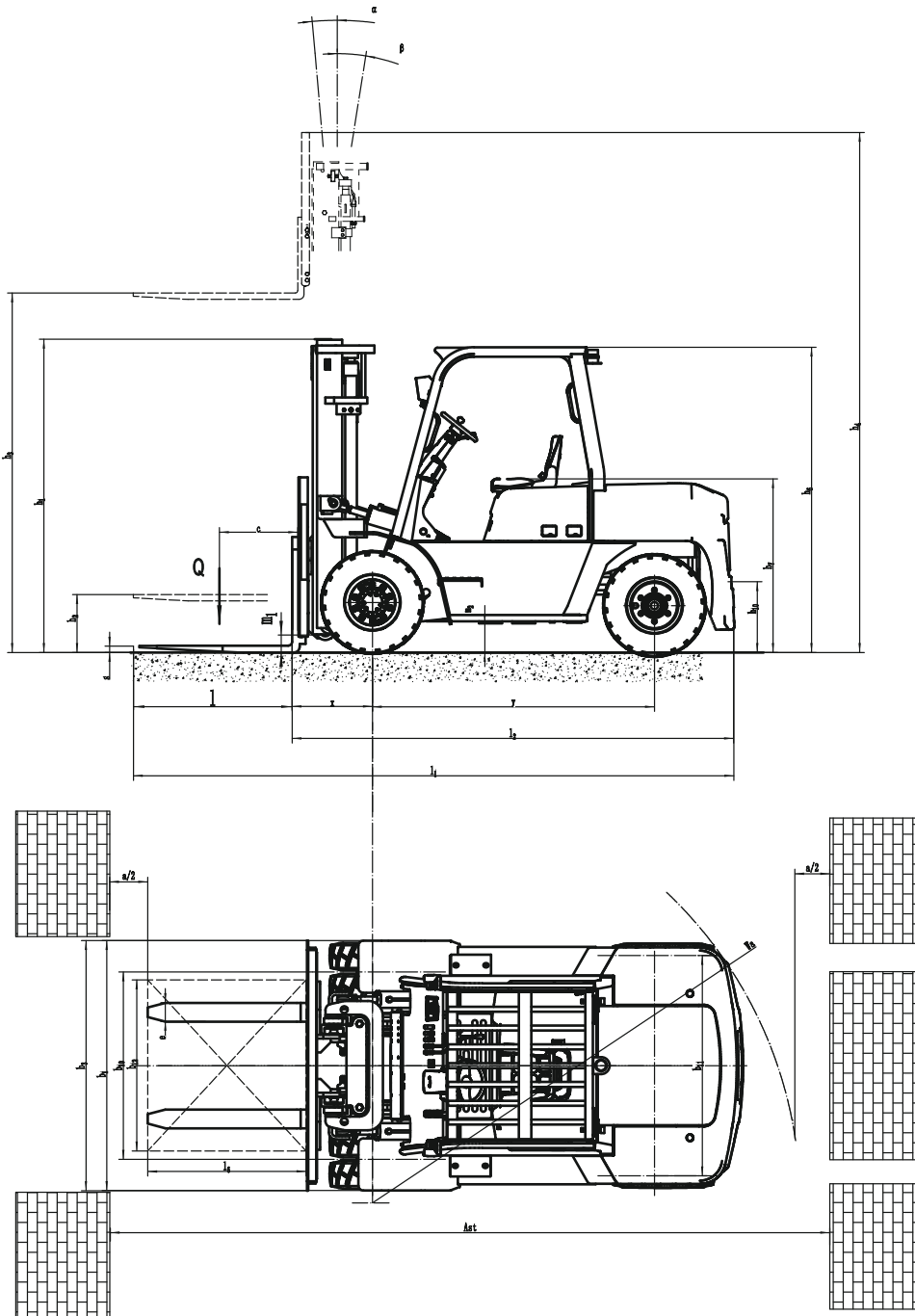

**RATED CAPACITIES AND LOAD CENTERS GRAPH**

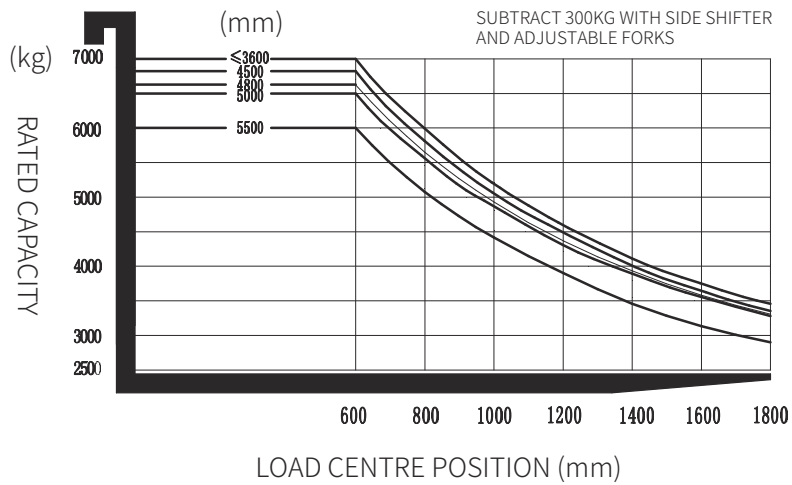

## Mast option:

Mast types	Lift height (h3)	Height, Mast			Height, Free lift(h2)	
		Height, mast lowered(h1)	Height, mast extended(h4)		No backrest	With backrest
	No backrest		With backrest	mm		
2-Standard Mast	3000	2510	4000	4430	130	130
	3300	2660	4200	4730	130	130
	3500	2760	4500	4930	130	130
	4000	3020	5000	5430	130	130
	4500	3310	5500	5930	130	130
	5000	3560	6000	6430	130	130
2-Free Mast	5500	3860	6500	6930	130	130
	3000	2480	4000	4430	1545	1090
	3300	2630	4300	4730	1695	1240
	3500	2730	4500	4930	1795	1340
3-Free Mast	4000	3030	5000	5430	2095	1640
	4500	2650	5070	5750	1740	1285
	4800	2765	5375	6050	1845	1390
	5000	2830	5575	6250	1910	1455
	5400	2965	6150	6830	2045	1590
	6000	3165	6570	7250	2245	1790

## Option:

No.	Optional items	EFL702
1.1	Fork dimension	●150*65*1220○150*65*1370○150*65*1520○150*65*1600○150*65*1820 ○150*65*2100○150*65*2200○150*65*2420○150*65*2500
1.4	Fork carriage width	●1845mm○Yes and can be customized
1.5	Fork carriage height	●1345mm○Yes and can be customized
2.5	Front wheel material	●Pneumatic○Solid○No-marking solid
2.6	Rear wheel material	●Pneumatic○Solid○No-marking solid
2.7	Battery capacity	●80V820AH
2.8	Charger	●80V200A ○80V130A+80V130A ○80V200A+80V200A
2.9	Battery indicator	●With time
2.10	Seat type	●Suspension
2.11	Attachments	●No○External shifter○Fork positioner
2.13	Traction pin	●Yes
2.14	Electrostatic chain	●Yes
3.5	Front lamp	●LED
3.6	Rear lamp	●No○LED
3.7	Warning lamp	●Yes
3.8	Steering lamp	●Yes
3.9	Blue lamp	●No○2 front○1 rear○2 front+1 rear
3.10	Area warning lamp	●No○1 left, 1 right (Red)
3.11	Rearview mirror	●1 in the middle○ Add 1 rearview mirror on both side
3.12	Buzzer	●Yes
3.17	OPS system	●Yes
3.23	Telematics	●Yes
4.3	Cabin	●No○Basic half cabin: window with wiper, ceiling, water injector for wiper ○upgraded half cabin: Basic half cabin +rear window with wiper, fan, water injector for wiper ○Full cabin: upgraded half cabin+doors, water injector for wiper
4.9	Heater	●No○Yes and not customized(Only for full cabin)
4.10	water injector for wiper	○Yes and not customized

Note: ● standard ○ option — NA

# Fully Closed Cabin (Option)

